

**ARKANSAS FIRE PROTECTION LICENSING BOARD
RULES AND REGULATIONS FOR SPRINKLER SYSTEMS
Effective August 1, 2008**

SECTION 1. SCOPE, PURPOSE AND FAIRNESS

1. **PURPOSE.** The purpose of these rules is to regulate persons engaged in the business of planning, selling, installing, maintaining, inspecting or servicing fire protection sprinkler systems in the interest of safe guarding lives and property pursuant to Act 743 of 1977 as amended (ACA 20-22-601 through 614).
2. **TITLE.** These rules shall be known and may be cited as the sprinkler rules and shall be administered by and through the Board.
3. **APPLICABILITY OF RULES.** These rules shall apply to all firms and persons engaged in the business and not to the general public.
4. **FAIRNESS NOTICE.** Notice by the Board as required by any provisions of statute or of these rule must be given by personal service of mail, postage prepaid, addressed to the person to be notified at his last known address of residence or business as it appears on the records in the office of the Board.

SECTION 2. DEFINITIONS

The following words and terms when used in these rules have the following meaning unless the context clearly indicates otherwise.

- a. Act 743 of 1977 – Fire protection requirements set forth by the State of Arkansas, of which the Arkansas Fire Protection Licensing Board was initiated. The Act is known as ACA 20-22-601 through 614 or Title 20, Subchapter 6, or loosely as *“The Act”*.

- b. **Authority Having Jurisdiction (AHJ) –***The organization, office or individual responsible for enforcing the requirements of a code or standard, or for approving equipment, materials, and installation, or a procedure.)*
- c. **Board –** the Arkansas Fire Protection Licensing Board
- d. **Certificate –** the certificate or registration issued by the Board *authorizing the applicant to engage in the business, whether relating to the individual RME, Inspector or the Fire Protection Sprinkler System contractor.)*
- e. **Certify –** to attest to the proper planning, installing, maintaining, inspecting or servicing of fire sprinkler systems by executing a contractor’s material and test certificate and attaching a completed service tag.
- f. **Certified Firm –** any business owned by an individual, partnership, corporation or association holding a current certificate of registration issued by the Board.
- g. **Demarcation –** *a point of a service, an isolating valve downstream of the domestic meter service, where the fire service line becomes a dedicated Fire Protection Sprinkler System supply line installed, or serviced by a Fire Protection Sprinkler System Contractor under the direct supervision and responsibility of a Fire Protection Sprinkler System Contractor as herein defined.*
- h. **Fire Protection Sprinkler System -** Interchangeable with “Fire Protection Sprinkler System”. An assembly of underground or overhead piping or conduits that convey water, with or without agents, to

dispersal openings or devices to extinguish, control or contain fire and to provide protection from exposure to fire or the products of combustion.

- i. ***Fire Protection Sprinkler Contractor*** – interchangeable with “contractor” or “the business”, means a ***Certified Firm*** – that offers to undertake, represent itself as being able to undertake the plan, sale, installation, maintenance, inspection or service of a ***Fire Protection Sprinkler System*** or any part of such a system.
- j. **Full-Time Employee** – an employee is considered to work full-time if the employee works an average of at least 30 hours per week.
- k. **Impairment** – a shutdown of a system or portion thereof. The two types of impairments are emergency and pre-planned.
- l. **Inspection** – a visual examination of a sprinkler system or portion thereof to verify it appears to be in operating condition, per codes and free from physical damage.
- m. **Inspector** – an experienced, trained and licensed individual employed by a ***Fire Protection Sprinkler System Contractor*** to perform inspections.
- n. **Installation** – the initial placement of a system or its extension, modification or alteration after initial placement.
- o. **Installer** – the installer refers to a licensed employee responsible for the initial installation of the fire sprinkler system. Anywhere installer is referred to in this

document it will be understood that an inspector may perform the duties.

- p. License – a written document issued by the Board to any person for the purpose of granting permission to such person to perform any act(s) for which authorization is required.**
- q. Licensed Individual – one who has met the requirements for and has been recognized by the Fire Protection Licensing Board, such as an RME or Inspector. (This term does not include the installer.)**
- r. Maintenance/Repair – to maintain in the condition of repair that provides performance as originally planned.**
- s. NFPA – National Fire Protection Association, Inc. – a nationally recognized standards making organization - # 1 Batterymarch Park, P. O. Box 9101, Quincy, Massachusetts 02269-9101.**
- t. NICET – National Institute for the Certification in Engineering Technologies whose expressed scope of certification is geared towards producing responsible, accountable layout technicians.**
- u. Organization – a corporation, partnership, other business association, a government entity or any other legal or commercial entity.**
- v. Person – a natural person, including any owner, manager, officer, employee or occupant.**
- w. Plan – to layout, detail, draw, calculate, devise or arrange an assembly of underground or overhead piping and**

- x. **Pre-planned** – a condition where a water based Fire *Protection* Sprinkler System or a portion thereof is out of service due to work that has been pre-planned in advance such as revisions to the water supply or sprinkler system piping.

- y. **Point of Service** – the point at which the underground piping for a sprinkler system, using water as the extinguishing agent, becomes used exclusively for the fire sprinkler system.

- z. **Responsible Managing Employee (RME)** – an individual(s) who shall be designated by each *Fire Protection Sprinkler System Contractor* to plan, sell, install, maintain or service a Fire *Protection* Sprinkler System Contractor on a full time basis to assure that each Fire *Protection* Sprinkler System as installed, maintained or serviced meets the standards as provided by law.

- z. **Standards** – those nationally recognized standards adopted herein.

- aa. **Service** – to inspect, test or repair fire sprinkler equipment in order to furnish or return the Fire *Protection* Sprinkler System to operational condition and may be in the form of maintenance contracts where applicable.

- bb. **Tags.** *See Section 5.4)*

- cc. Test – the act of subjecting a Fire *Protection* Sprinkler System to any procedure necessary to insure its proper operation or installations.

SECTION 3. APPLICATION

The rules and regulations shall have uniform force and effect throughout the State, Municipalities or counties and may require additional certificate of registration or licenses or may require certified firms to obtain permits or pay fees beyond the scope of these rules and regulations.

These rules and regulations do not apply to a person or organization that only sells or supplies products or materials to a certified firm, special agent fire suppression system, a regular employee of a certified firm, inspection activities conducted as part of an insurance or engineering survey, inspection activities performed by a government official as part of code enforcement activities, routine observation of the condition of fire sprinkler equipment by the maintenance staff of the owner or tenant and nothing herein shall be deemed to limit or restrict the practice of engineering by licensed or certified professional engineers.

1. Adopted codes – the Board adopts, *in its entirety, the Arkansas Fire Prevention Code, 2007 edition and documents referenced therein*) published by and available from the ICBO Resource Center, 9300 Jollyville Road, Suite 101, Austin, TX 78759-7455, (512-794-8700, Fax 343-9116, 800-252-3602. A copy of the codes shall be kept available for public inspection in the office of the State Fire Marshal.
2. Adopted Standards. The Board adopts in their entirety, the documents referenced by the adopted code and summarized in Chapter 45 of that code. To the extent there is not contradiction between the adopted code and copywriters standards published by and available from, the National Fire Protection Association, Inc. # 1 Batterymarch Park, P. O. Box 9101, Quincy, Mass. 02269-9101, 1-800-344-3555,

such NFPA standards, even though referenced in part, are entirely adopted. Where the adopted code does not reference a standard or edition, the most recently published edition of the standard shall be the one adopted by the Board. A copy of the standards shall be kept available for public inspection in the office of the State Fire Marshal.

3. **Approved Certification Organizations.** The Board approved the National Institute for Certification in Engineering Technologies (NICET) as a nationally recognized testing standards organization for certifying licensed applicants.
4. **Explanation of Roles.**
 - a. **Owner's Role.** The responsibility of properly maintaining a water based fire system shall be that of the owner(s) of the property. By means of periodic inspections, tests and maintenance, the equipment shall be shown to be in good operating condition or any defects or impairments shall be revealed. Inspection, testing and maintenance shall be implemented in accordance with procedures meeting or exceeding those established in this document and in accordance with the manufacturer's instructions. Personnel who have developed competence through training and experience shall perform the task. See Section 5.

The building owner or occupant shall not make changes in the occupancy, the use or process, or the materials used or stored in the building without evaluation of the fire system for their capability to protect the new occupancy, use or materials. The evaluation shall consider factors that include, but are not limited to, the following:

1. **Occupancy changes such as converting office or production space into warehousing.**

- 2. Process or material changes such as metal stamping of molded plastics.**
- 3. Building revisions such as relocated walls, added mezzanines and ceilings added below sprinklers.**
- 4. Removal of heating systems in spaces with piping subject to freezing.**

Where changes in the occupancy, hazard, water supply, storage, commodity, storage arrangement, building modification or other conditions that affect the installation criteria of the system are identified, the owner or occupant shall promptly take steps (such as contacting a qualified contractor, consultant or engineer) to evaluate the adequacy of the installed system in order to protect the building or hazard in question. Where the evaluation reveals a deficiency causing a threat to life or property, the owner shall make appropriate corrections. All requirements of the authority having jurisdiction shall be followed.

The owner shall maintain records. Records shall indicate the procedures performed (inspection, test or maintenance), the organization that performed the work, the results, the date and the inspector or RME license number. Original records shall be retained for the life of the system. Subsequent records shall be retained for a period of one year after the next inspection, test or maintenance required by the standard.

To avoid false alarms where a supervisory service is provided, the alarm receiving facility shall always be notified by the owner or designated representative before conducting any test or procedures that could result in the activation of an alarm or after such test or procedures are concluded.

- b. Contractor's Role.** In order to fulfill the intent of the owner's roles, a specialized contractor may be hired who satisfies the role of employing "personnel who have developed competence through training and experience". The contractor then assumes responsibility for the maintenance, inspection, servicing or installation of the system to the extent expressed in the contract between the two parties. The contractor's inspector or RME shall furnish a license number for all hired work and shall fax a copy of the completed forms to the Licensing Board.
- c. Failure to comply by sending such completed forms shall result in a fine of \$50.00 for the first offense and will add \$50.00 per incident thereafter, second offense is \$100.00; third offense is \$150.00, etc... The Board reserves the right to waive such fines, being subject to the contractor's hearing.**
- d. RME Role.** All drawings, executed by a contracting firm requires authentication from an RME licensed with the Board who thus signified the drawings have satisfied the requirement of the contract and either have been submitted or approved by the applicable authorities having jurisdiction. The RME is physically involved with insuring the Design Process has been executed in a manner agreeable with the rules and regulations. The RME may perform the role of an inspector in addition to the primary role expressed above.
- e. Installer's Role.** The Installer receives approved drawings as signed off by the company's RME and is in charge of installing the sprinkler system according to such drawings. Once completed, the Installer must perform testing and provide documentation for such testing in accordance with the appropriate NFPA standard. The role of this individual is "installation" and this individual's

competency falls under the jurisdiction of the company's RME.

- f. **Inspector's Role.** The Inspector is an experienced and trained individual who is employed by a *Fire Protection Sprinkler System Contractor* to visually examine and verify the installed system appears to be in operating condition and free of physical damage in accordance with the nationally adopted NFPA 25 standard. The Inspector also acts as a liaison and informant for the fire department by signing systems off as described in the tagging system later described in this document. Where the installer's initial installment is covered under the contractor's and manufacturer's warranties the inspector must have the competence to provide assurance that the system components are working properly even after the warranties have been exhausted.

SECTION 4: REGISTRATION, LICENSING, FEES

1. Certificate of Registration

- a. **Required.** Each firm engaged in the business shall have a certificate of registration issued by the Board.
 - i. Each firm shall have at least one full time licensed RME who shall be properly equipped to perform the act or acts authorized by its certificate.
 - ii. Certificate holders shall be responsible for the acts of their agents and employees for purposes of these rules, including the taking of administrative action by the Board.
- b. **Business Location.** A specific location shall be maintained by each certified firm which shall be indicated on the certificate.
- c. **Posting.** Each certificate shall be posted conspicuously on the premise.

- d. **Change in ownership.** The change of a firm's ownership invalidates the current certificate. To assure continuance of the business, an application for a new certificate must be submitted to the Board fourteen (14) days prior to such change.
- e. **Change in corporate Officers.** Any change of corporate officers must be reported in writing to the Board within fourteen (14) days. This change does not require a revised certificate.
- f. **Duplicate certificates.** A duplicate certificate may be issued upon receipt of written notification of the loss or destruction, without delay, accompanied by the required fee.
- g. **Revised certificate.** The change of a firm's name, location or mailing address requires a revised certificate. Certificates requiring changes must be surrendered to the Board within fourteen (14) days after the change requiring the revision. The certificate holder must submit written notification of the necessary change with the surrendered certificate accompanied by the required fee.
- h. **Minimum Age.** A certificate shall not be issued to any person who is under 18 years of age.
- i. **Termination of Registered firm's RME.** Upon termination of the registered firm's RME, the firm shall submit to the Board, in writing, within forty-eight (48) hours and have a full time employee submit for a new RME license within thirty (30) days.
- j. **Nontransferable.** A certificate is not transferable from one firm to another.

2. Responsible Managing Employee *or Inspector's* License

- a. **Required.** Each person designated as a responsible managing employee *or Inspector for a Fire Protection Sprinkler System Contractor*) must have a license issued by the Board.

- b. **Full Time Employee.** A licensee shall be a full time employee of a certified firm.
- c. **Posting.** Wall licenses shall be posted conspicuously on the premise of the firm's business location.
- d. **Pocket License.** The pocket license is for identification purposed only as long as such license remains valid and the firm reflected on the license employs the license holder.
- e. **Duplicate License.** A duplicate license must be obtained from the Board to replace a lost or destroyed license. The license holder must submit written notification of the loss or destruction without delay accompanied by the required fee.
- f. **Revised License.** The license holder must submit written notification of the necessary change with the surrendered license accompanied by the required fee.
 - i. License requiring change(s) due to a change of home or mailing address must be surrendered to the Board within fourteen (14) days after the change requiring the revision.
 - ii. License requiring a change due to a change from one registered firm to another must be submitted in writing to the Board within forty-eight (48) hours.
- g. **Minimum Age.** A license will not be issued to any person who is under 23 years of age.
- h. *Inspectors must meet the criteria outlined in Exhibit F, Table A unless waived, taken exception to, or otherwise deemed equivalent as determined by the Board.*
- i. **Restrictions**
 - i. A license does not authorize anyone engaged in the business to enforce these rules or to

- enter any building without the owner's permission.
 - ii. Licensees shall not permit the use of their license by other persons.
 - iii. A licensee shall not engage in any act of the business unless employed by a certified firm.
 - iv. Nontransferable. A license is not transferable from one person to another.
- 3. **Alteration of Certificates or License.** Alteration of such documents renders them invalid and is the basis for administrative action pursuant to Act 743 of 1977 as amended.
- 4. **Applications.**
 - a. **Certificate of Registration.**
 - iii. Applications for certificates shall be in writing on forms provided by the Board and accompanied by the required fee.
 - iv. Applications must be signed by the sole proprietor, by each partner of a partnership or by an officer of a corporation or organization and where applicable, accompanied by evidence of registration as an Arkansas Corporation or evidence of registration with the Arkansas Secretary of State as a foreign corporation. The application shall also include written authorization by the applicant permitting the Fire Marshal or representative to enter, examine and inspect any premises, building, room or establishment used by the applicant while engaged in the business to determine compliance with the provisions of Act 743 of 1977 as amended.
 - b. **Insurance Required.**

- i. **The Board shall not issue a certificate of registration under these rules unless applicant files with this office proof of liability insurance as required in Act 743 of 1977 as amended.**
 - ii. **Each certified firm shall maintain in force and on file in the Board's office the certificate of insurance as required. Failure to do so will be cause for action to suspend the firm's certificate.**
 - c. **Responsible Managing Employee License.**
 - i. **Original and renewal applications for a license from an employee of a firm engaged in the business shall be on forms provided by the Board and accompanied by the required fee.**
 - ii. **One of the following documents must accompany the application to evidence technical qualifications for a license.**
 - 1. **A copy of NICET's notification letter regarding the applicant's successful completion of the examination requirements for certification at Level III for fire protection automatic sprinkler system layout.**
 - 2. **Individuals applying for a license on or before October 1, 1998 without completing NICET Level III examination requirements may be issued a license if they otherwise qualify, according to the provisions of Section 6F (3) of Act 702 of 1985. At the time of renewal of such license, applicant must accompany the renewal application with a copy of NICET's notification letter regarding the applicant's successful completion of the examination**

requirements for certification at Level III.

3. A copy of a diploma showing the completion of a Bachelor of Science Degree in Fire Protection Engineering (or Engineering Technology) from a recognized institution, along with a signed affidavit from an Arkansas licensed sprinkler contractor stating the individual has a minimum of three (3) years subsequent experience in fire sprinkler layout.

5. Examinations.

- a. Each applicant for a license shall take and pass, with at least 90% grade, an examination covering these rules. The Board shall set the content, frequency and location covering these rules and Act 743 as amended. In addition to these requirements, Inspectors must pass an examination covering the *current editions* of NFPA 25 and NFPA 13.
- b. Applicants not passing the examination must file a re-examination application accompanied by the required fee.
- c. A person whose license has been expired for two years or more and make application for a new license must take and pass another examination. No examination is required for a license renewed within two year of expiration.

6. Fees.

- a. Every fee required in accordance with the provision of Act 743 of 1977 as amended and these rules shall be paid by money order or check. Money order or check shall be made payable to the Fire Protection Licensing Board.

- b. Fees shall be paid at the office of the Board in Little Rock, Arkansas or mailed to an address specified by the Board.
- c. Fees shall be as follows:
- i. **Certificate of Registration**

Initial Fee	\$700.00
Renewal Fee	\$700.00
Application Fee	\$100.00
Branch Office (if using Different name	\$ 28.00
<i>Update/Revision</i>	<i>\$ 30.00</i>
 - ii. **Responsible Managing Employee License**

Initial Fee (which includes 1 st exam Fee)	\$300.00
Renewal Fee	\$300.00
 - iii. **Inspector License**

Initial Fee (which includes 1 st exam fee)	\$150.00
Renewal Fee	\$150.00
 - iv. **Other Fees**

<i>Transfer/Duplication</i>	<i>\$ 30.00</i>
Other requested changes to Certificate or License	<i>\$30.00</i>
Examination Fee	\$ 28.00
- d. Late fees are required of all certificates or license holders who fail to submit renewal applications on or prior to their expiration date *of June 30*.
- e. A renewal application accompanied by a required fee and deposited with the United States Postal Service is deemed to be timely filed, regardless of actual date of delivery,

when its envelope bears a legible postmark date which is on or before the expiration date of the certificate being renewed.

- f. A certificate or license expired for two years or more cannot be renewed.
- g. Certificates and license expired for less than two years may be issued. Renewal fees for certificates or licenses expired for less than two (2) years are composed of renewal and late fee and shall be determined in accordance with the following schedule:

Expired 1-90 days 1 renewal fee + 1/2 initial fee=Total fee due

Expired 90-365 days 1 renewal fee + 1 initial fee = Total fee due

Expired 366 days–2 years –2 renewal fees + 1 initial fee=Total fee due

(Example: 1-90 days Company

Renewal Fee \$700.00 + \$350.00=\$1050

RME:

Renewal Fee \$300.00 + \$150.00=\$450.00

Inspector:

Renewal Fee \$150.00 + \$75.00 = \$225.00

- h. After two (2) years a company would be treated a a new company. RME(s) and Inspector(s) shall re-test to receive a license.

SECTION 5. PROCEDURES

1. Installation, Inspection and Service.
 - a. All sprinkler systems installed under Act 743 of 1977 as amended shall be under the supervision of a license Responsible Managing Employee.
 - b. Beginning at the *demarcation valve* where water is used exclusively for fire sprinkler systems *installation, testing and or servicing shall be executed by a Fire Protection Sprinkler*

System Contractor or under the direct supervision thereof and shall be in compliance with the adopted code and standards).

Direct Supervision is herein defined as on sight coordination, instruction and evaluation given by the Fire Protection Sprinkler System Contractor designated foreman to ensure that all work is installed per any adopted codes and standards. Such supervision includes, but is not limited to, assurance, by inspection, that listed materials and proper restraints are used, such work is flushed, hydrostatic testing of 200 psi for 2 hours is performed, that the work is hydraulically calculated and Contractors Material Test Certificates reference any subcontracted work, who performed such work (with all contact information) and the exact scope of such work.

- c. Installers are to complete the contractor's Material and Test Certificate upon completion of the installation.
- d. A licensed individual shall distribute a contractor's Materials and Test Certificate as follows:
 - i. Original copy retained by the installing company.
 - ii. Second copy kept at the site after completion of the installation.
 - iii. Third copy to be sent to the insurance authority having jurisdiction within ten (10) days after completion of the installation.
 - iv. Fourth copy of the sent to the Licensing Board.
- e. A licensed inspector, employed by a *Fire Protection Sprinkler System Contractor*, shall conduct inspections in compliance with NFPA 25. (Forms may be obtained from NFPA 25.)
 1. A written inspection report shall be completed and copies filed with the following:

- i. Owner, occupant or other designated responsible person
 - ii. Local Fire Authorities having jurisdiction
 - iii. The State Licensing Board
2. The AFSA or NFSA sample forms in the Appendix of NFPA 25 are **MANDATORY FORMS** required by the State of Arkansas when inspecting a fire Sprinkler system. Other inspection forms are not permitted.
- f. Service which includes maintenance, where required, shall be conducted by a *Fire Protection Sprinkler System Contractor* and in compliance with the appropriate adopted standards.
- g. Complete records shall be kept of the tests and operations of each system. The records shall be available for examination by the Fire Marshal or his representative.
- h. Fire Pumps. Fire Pump installation, inspection and/or testing must be performed or officially supervised by a licensed *Fire Protection Sprinkler System Contractor* whose field representative must demonstrate proper training *recognized by the Board*.
- i. *Backflow Prevention.*
 - a. *Adding Backflow Prevention to Existing Facilities. Where backflow preventers are required to be installed on existing systems, the owner must have the system re-calculated with the loss of the backflow preventer. For pipe schedule systems, the pipe schedule method of evaluating the additional friction loss is acceptable.*
 - b. *Backflow Prevention Installation. Due to the necessity for hydraulic calculation, all Backflow Preventers that are installed downstream of the point of demarcation must be installed by a Fire Protection*

Sprinkler System Contractor and calculated by same Fire Protection Sprinkler System Contractor unless otherwise calculated by an Engineer licensed in the State of Arkansas. Backflow Preventers must be hydraulically calculated at the maximum flow condition for the fire sprinkler system.

c. Backflow Preventers installed in Force Pump Supply. Per NFPA 20, Backflow preventers must be installed downstream of the fire pump installation unless required to be otherwise by the State Health Department or local municipalities. Such Backflow Preventers shall be listed to accommodate Fire Pump Churn pressure in addition to any other supply pressure obtained for the system.).

c.1. A licensed company may elect to utilize a distributor or manufacturer's representative to perform these services provided it is under the supervision of an Arkansas licensed *Fire Protection Sprinkler System Contractor*. Documentation of proper training and/or a letter from a distributor or manufacturer's representative must be submitted to the Board Reference to Exhibit *F* Table B.

c.2. Once the Fire Pump inspection, installation and testing is completed an AFSA or NFSA form shall be completed, *retained on file by the contractor* and furnish to:

- i. the business owner**
- ii. the Fire Marshal**

- j. Stand pipes shall be installed by a licensed Fire Protection Sprinkler System Contractor per Act 1073 of 2003.*
- k. Multipurpose systems are residential type systems where domestic plumbing and fire sprinkler work are highly integrated. Any fire sprinkler portion of such system must be performed by a licensed Fire Protection Sprinkler System Contractor or under the direct supervision, as defined in Section 5.1.b. (Reason: AFSA's concern relating to the integrity of such systems as relayed in a specially issued white paper on the subject. It is probably in the best interest of our industry to disallow these systems, but if we do, concern has been expressed that such systems may find a back door through the plumbing law.*
- l. Elevator Safety falls under the jurisdiction of the Arkansas Department of Labor, Elevator Safety Division and shall adhere to Rules and Regulations adopted by the Arkansas Elevator Safety Board. Although NFPA 13 allows the omission of fire sprinklers meeting ASME/ANSI A17.1 requirements, the portion of this document dealing with the installation of pipes in hoistways and machine rooms, namely ASME/ANSI A17.1a of 1998, rule 102.2 (now replaced by the equivalent reference from the 2004 edition), list 5 requirements which, alongside additional concerns of the Elevator Safety Division, can be satisfied by following the guideline shown below:*

Elevator Pits require fire sprinklers due to the accumulation of debris in the pit. Such fire sprinklers require a shutoff valve with a tamper switch, but do not require any monitoring of flow. The supply shall not enter

the elevator shaft more than 6" above the finished floor level and once entering must tightly hug the wall of the pit (ideally not on the same wall as the hydraulic equipment). The elevator sprinkler shall be Intermediate temperature, Ordinary Response and located 16" to 20" above the pit floor.

Elevator Machine Rooms require both shutoff valves with temper switches AND a flow switch to be wired by a licensed alarm company IF shunting is required. The water flow switch shall be set to Zero Delay in order to shunt the main power supply and Car Lighting Circuit. All flow switches must be testable (if providing a plugged outlet, place the outlet at least 1 foot away from the water flow switch where conditions allow). The Elevator Machine Room sprinkler shall be 175 deg to 225 deg, Ordinary Response, giving the 135 degree heat detector time to return the elevator to the designated floor with open doors, remaining in place, until Phase II Recall initiated by the Elevator's keyed switch. The time delay between heat sensor activation and higher response time and higher temperature rated fire sprinkler allows electrical power to shut down prior to fire sprinkler activation. See Exhibit G.

Sprinklers shall not be required in the tops of elevators unless required by NFPA 13 (i.e. for Freight Elevators). If a fire sprinkler is installed in the hoistway, it shall be installed as specified for the Elevator Machine Room and a heat detector at the top of the hoistway shall perform the same shunting functionality as described for the Machine Room.

- m. The Department of Human Services (DHS) does not recognize concessions made by the*

codes and standards with regards to Fire Retardant Treated Wood (FRTW) and therefore, where projects fall under the jurisdiction of DHHS, please consult with the Director of Human Services, prior to attempting such work.

- n. Engineers, Fire Officials, Insurers, and other AHJs are the recognized interpreters of Codes and Standards adopted by this Board and govern the parameters of design for which the Fire Protection Sprinkler System Contractor and RME are responsible for fulfilling.*

2. Sprinkler System Plans.

- d. Sprinkler working plans and hydraulic calculations shall be submitted to a reviewing authority, where applicable, for all systems installed in a building prior to completion of installation.**
- e. Subsequent alterations or additions shall be legibly noted on updated plans. When an alteration consists of 20 sprinklers or less and all floor area were *calculated with such alterations accounted for*, updated plans are not required. Updated plans are required for all alterations consisting of more than 20 sprinklers. Additions to systems protecting unprotected areas also require updated plans.**
- f. Plans shall bear the signature of the licensed responsible managing employee, his license number, the date of installation, alteration or addition and the certificate of registration number of the certified firm.**

3. Hydraulic Placard Standards and Requirements (See Exhibit "A" for example).

- a. Every new and remodeled system shall receive a self-adhesive hydraulic placard that is to be placed in plain view on the system riser.**

- b. The placards shall be no less than 0.002" in thickness, made of an aluminum foil type material.
- c. Adhesives shall be 3M or equivalent permanent pressure sensitive backing.
- d. Size shall be no less than 5" wide by 7" long.
- e. Each placard shall contain the following information:
 - i. System number
 - ii. Remote area location
 - iii. Number of sprinklers calculated
 - iv. Hazard group
 - v. Commodity protected
 - vi. Maximum storage height
 - vii. Density
 - viii. Design discharge area
 - ix. GMP discharge
 - x. Residual pressure at the base of the riser
 - xi. Un-sprinkled areas of the facility
 - xii. Date of installation
 - xiii. The statement "DO NOT REMOVE, DESTROY OR OBSTRUCT BY ORDER OF THE STATE FIRE MARSHAL" in bold type and font size shall be no smaller than 16.
 - xiv. RME name and number
 - xv. Company certificate of registration number
 - xvi. Arkansas Contractors License number
 - xvii. Fire Sprinkler company name, address and telephone number
 - xviii. Codes, edition(s) and year system installed by
- f. Wording on the placard shall be legible and permanent so as not to rub off.
- g. *Fire Protection Sprinkler System contractors shall submit samples of placards to the Arkansas Fire Protection Licensing Board for*

approval at the time of licensing and for annual license renewals.

4. Overview of Tagging System

- a. **Green Service Tag.** Any system that is green tagged is understood to have successfully passed inspection by a licensed individual utilizing *the state standard* inspection forms *NFSA or AFSA Forms*. All non-emergency impairments must be noted in the comment section of the tag.
- b. **Yellow Tag.** Any system that is understood to have impairments that do not merit a Red Tag, such as *manufacturer's recalls, missing head boxes or contents thereof, inoperable alarm functions, areas with improperly spaced fire sprinklers, where fire sprinklers have been painted and require replacement, and other such impairments that would not be anticipated to substantially diminish the system's ability to perform its intended function – protection of the occupants and/or building.*
- c. **Red Tag.** Any system that is red tagged is understood to be emergency impaired and therefore would not be acceptable to connect to in the case of emergency operations.
- c. **Impairment.** A shutdown of a system or portion thereof. The two types of impairments are as follows:
 - i. **Emergency.** A condition where a water based *Fire Protection Sprinkler System* or portion thereof is out of order due to an unexpected occurrence, such as a ruptured pipe, an operated sprinkler, or an interruption of the water supply to the system. All impairments that would interfere with the fire department's ability to rely upon the fire sprinkler system's reliability are

considered to be Emergency Impairments. (Example: *a potential or immediate hazard that jeopardized water flow conditions in the fire department connection supply line, bad fire department connection threads, an obstruction in the FDC supply, any openings in the system (whether piping or sprinklers, defective FDC check valves, etc.)*)

ii. Pre-Planned. A condition where a water based *Fire Protection Sprinkler System* or a portion thereof is out of service due to work that has been planned in advance, such as revisions to the water supply or sprinkler system piping.

d. Authorized Tag Personnel. Only the following persons are authorized to *attach, remove, or re-attach service tags, yellow tags or red tags.*

i. *A Fire Protection Sprinkler System Contractor's RME or inspector)*

ii. By order to the State Fire Marshal

iii. By order of the local Fire Authority Having Jurisdiction

iv. By order of the State Fire Protection Licensing Board or its designated employee

5. Service Tag (See Exhibits "*C*" and "*D*")

a. After installation *and after each* service, maintenance or inspection a *new* "service tag" shall be completed in detail indicating all work that has been done and then attached to the system in such a position as to permit convenient inspection and not hamper actuation or operation of the system.

b. *DELETE and Re-number remaining items: A new service tag shall be attached each time*

an inspection, service or maintenance is performed and the criteria of the above paragraph exist.

- b. *Service tags are to be attached when the selected inspection form (AFSA or NFSA format) is completed and impairment have not been found during the inspection.***
- c. *Service tags, Yellow Tags, and Red Tags shall be 5 ½ inches in height and 2 5/8 inches in width. Service tags shall be green in color.***
- d. *MOVED FROM 5.f to 5.d All tags must utilize a "punch out" system for dating and may be printed and established for a period of five (5) years. After each printing one tag shall be sent to the Fire Protection Licensing Board.***
- e. *Service Tags, Yellow Tags, and Red Tags shall bear the following information:***
 - i. *Printed at the top of the tag in all capital letters in at least 36 point bold face type will be the following: "DO NOT REMOVE BY ORDER OF THE STATE FIRE MARSHAL".***
 - ii. *Name, address, telephone number and certificate number of the firm performing the installation, service, maintenance or inspection.***
 - iii. *Name and license number of the firm's Inspector or RME clearly printed (hand printing not allowed).***
 - iv. *Signature of the person performing the work.***
 - v. *Day, month and year the work was completed (may be punched)***
 - vi. *Type of work performed – installation, service, maintenance or inspection (may be punched)***
 - vii. *Name and address of the property owner where the work was performed.***
 - viii. *Description and address of the property where the work was performed.***

- ix. Comments (shall include 3 or more lines).
- f. If *non-emergency* impairments are found, the RME or *inspector* must notify the building owner or his representative. *In addition, the authority having jurisdiction shall be notified in writing and/or a copy of the completed tag (front and back) is to be sent to him noting all impairments. This information must be sent by mail or fax with fourteen (14) business day of the inspection.*
- g. **MOVED FROM 6.a** – If impairments are found in the system that constitute an emergency impairment, as defines in NFPA 25, then the RME or the inspector shall complete and attach a Red Tag in such a position as to permit convenient inspection and not hamper actuation or operation of the system *and one laminated Red Tag is to be placed on the exterior fire department connection (peel and seal clear laminate is acceptable).* After notifying the owner and discussing the deficiencies, the RME or inspector shall immediately notify the local AHJ *within 24 hours, either by telephone or in writing, and follow up by way of sending a copy of the inspection report or a copy of the completed tags (front and back) by mail, email or fax within 5 business days of the inspection.*
- h. *Where impairments are found, a service tag must not be installed on the system until corrections have been made, at which time the system must be re-inspected until it id found to be free of impairments.*

SECTION 6. POWERS AND DUTIES OF THE BOARD

- a. The Fire Protection Licensing Board shall issue no certificate of registration to a firm where the issuance of such license shall be confusing to the

public. It shall be the duty of the person requesting a certificate of registration to inquire of the Board concerning the acceptability of the proposed company name.

- b. **Enforcement.** The failure to comply with provisions of these rules by certificate holders or licensees may subject them to Board action including but not limited to, suspension, fine, revocation or refusal to issue or renew a license or certificate of registration.
- c. **Severability.** If any provision of these rules or the application thereof to any person or circumstance is held invalid for any reason the invalidity shall not affect the other provisions or any other application of these rules which can be given effect without the invalid provisions or application. To this end all provisions of these rules are declared to be severable.

SECTION 7. BOARD HEARINGS, COMPLAINTS, INVESTIGATIONS

- a. **Complaints.** Any and all complaints falling within the jurisdiction of the Board, which individual's make, must be in written form. The Board staff will date stamp the complaint and a complaint number will be assigned when received in the Board office.
- b. ***Jurisdiction. Failure to meet any rules, regulation, requirement or implication thereof clearly written or illustrated in this document, whether in its body, exhibits, or whatever portion thereof, is subject to fines and penalties and falls within the jurisdiction of this Board.***
- c. **Investigation.** The Board may, on its own motion, initiate investigations. The Board after reviewing the complaint *with Board Counsel will determine whether there is sufficient evidence to make a prima facie case and* proceed to investigate the allegations.

d. **Hearings.** If it is determined there is a prima facie case, that a licensee or individual has violated laws under the Board's jurisdiction, the Board will cause a Notice of Hearing to be issued. The Notice of Hearing will contain information as required by Arkansas Administrative Procedures Act.

d.1. The Notice will be served on the respondent by U. S. Mail or by personal delivery at least twenty (20) days before the scheduled hearing. Notice shall be deemed sufficient if the Notice is mailed to the person at his or her address of record with the Board.

d.2. Any and every Notice, Order or other instrument herein required to be forwarded or sent to any person concerning a complaint or hearing shall be deemed sufficient if addressed to the person at his or her address as last furnished to the Board, in a sealed envelope and delivered by Certified Mail, postage prepaid.

d.3. At any and all meetings of the Board at which a hearing is to be held on any complaint previously filed the same shall be set down for a day certain by the Board, at least ten (10) days prior to any such hearing date.

d.4. The Board shall, at least 20 days prior to any such hearing date, notify all persons entitled to notice thereof, by certified mail of the order of the Board setting such complaint for hearing. Said Notice shall contain the place and approximate time of said hearing, a brief and concise statement of the facts forming the basis of the complaint, the provisions of the law or the rules and regulations thought to be involved therein and shall be executed by the Board, dated and sealed with the official seal of the Board.

d.5. Any licensee complained against and to be heard or any complaining witness, may, by written petition signed and dated, invoke the aid of the Board in the procurement of any witness he or she may desire to be present and testify at any such hearing, such petition to be filed with the Board at least five (5) days prior to such hearing date. Any and all cost anticipated must be deposited with the Board at the time of any such request.

d.6. Every pleading, motion or other document and every request to the Board must be filed with the Board in writing, signed, dated and in quadruplicate.

d.7. Hearings before the Board shall be presided over by the Chairman, although the Board may from time to time utilize hearing officers. Testimony before the Board shall be made under oath and shall be steno graphically reported.

d.8. Each and every hearing of the Board after being duly called to order, shall begin with a statement by the Chairman or Vice-Chairman, as to the nature of the cause to be heard, an inquiry of the parties present as to whether each is prepared to proceed and thereafter the cause, shall proceed with the presentation of evidence for and on behalf of the complainant. At the conclusion of such evidence the person complained against may then proceed to introduce evidence in contradiction, after which rebuttal testimony may be offered.

d.9. Either oral or written argument on the issues raised may be called for or dispensed with by the Chairman or discretion of the Board.

d.10. At any hearing both the licensee and complaining witness involved may be present in

the hearing room during the entire proceedings and shall have the right to cross-examine any witness and to examine any document or evidence submitted.

d.11. The Board will receive into evidence all affidavits, depositions, certified copies of documents, Photostats of official records and exhibits therewith introduced, together with such other evidence as may be administered by law. The Board shall give to such evidence such weight as they shall determine just and proper.

d.12. Respondents before the Board shall be entitled to be represented by counsel, shall be allowed to cross-examine witnesses and shall be allowed to present testimony, photographs and other exhibits which are determined to be admissible by the Chairman or Hearing Officer.

d.13. No attorney shall withdraw his appearance in any case before this Board except by leave of the Board after notice served by him or his client and counsel for the Board.

d.14. At the conclusion of the evidentiary portion of the hearing, the Board will conduct deliberations. At the close of the deliberations, the Board will make Findings of Fact, Conclusion of Law and Disciplinary Orders, if appropriate.

d.15. The Board shall file its written findings and conclusions as to all hearings, same to be signed by the Board. A copy of such Order shall be sent to the licensee involved by certified mail.

e. Alternate Proceedings. Prior to proceeding to a formal adjudicative hearing, the case will be reviewed by an ad hoc committee to determine whether summary proceedings should be invoked.

Members of the committee will be appointed by the Chairman and will in most cases include the State Fire Marshal, the Board Executive Director and/or Investigator and the Board's Legal Counsel. If the committee determines that violations, if proved, would not warrant license revocation or a fine in the amount greater than one thousand (\$1,000) dollars, the committee may recommend the complaint be handled in a summary manner. The decision will be referred to the Chairman for acceptance or rejection.

e.1. If the Board decides to utilize alternative proceedings, the respondent will be notified by mail that the Board has learned that he or she has engaged in actions which violate the licensing law and it is recommended that under all the circumstances appropriate sanction is a fine of one thousand (\$1000) dollars or less. The Notice will further inform the respondent that he has the right to reject the proposed fine and have a full evidentiary hearing.

e.2. The respondent will be provided with a document which requests that he admit or deny violation of the Licensing Law and to further accept or reject the proposed penalty. The respondent will indicate he understands he has the right to a full evidentiary hearing before the Board and that he elects not to exercise that right.

**ARKANSAS FIRE PROTECTION LICENSING BOARD
HYDRAULIC PLACARD
EXHIBIT "A"**

FIRE SPRINKLER SYSTEM HYDRAULIC DESIGN & HAZARD CRITERIA	
FIRE SPRINKLER SYSTEM NUMBER	<input type="text"/>
REMOTE AREA LOCATION	<input type="text"/>
NO. OF SPRINKLERS CALCULATED	<input type="text"/>
HAZARD GROUP	<input type="text"/>
COMMODITY PROTECTED	<input type="text"/>
MAXIMUM STORAGE HEIGHT	<input type="text"/>
BASIS OF DESIGN	
1. DENSITY	<input type="text"/> GPM SQ. FT.
2. DESIGNED AREA OF DISCHARGE	<input type="text"/> SQ. FT.
SYSTEM DESIGN	
1. GPM DISCHARGE	<input type="text"/> GPM
2. RESIDUAL PRESSURE AT THE BASE OF THE RISER	<input type="text"/> PSI
ARE THERE ANY AREAS OF THIS FACILITY NOT SPRINKLED	<input type="text"/>
DATE OF INSTALLATION	<input type="text"/>
RME #	<input type="text"/>
COMPANY CR #	<input type="text"/>
AR CONTRACTORS LICENSE #	<input type="text"/>
DO NOT REMOVE, DESTROY, OR OBSTRUCT BY ORDER OF THE STATE FIRE MARSHAL.	
COMPANY NAME	
ADDRESS	
PHONE NUMBER	

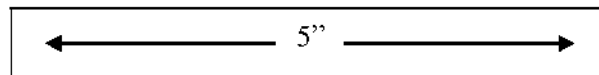
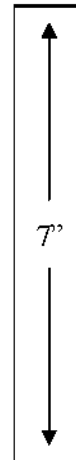

Actual Size

**ARKANSAS FIRE PROTECTION LICENSING BOARD
SERVICE TAG
SERVICE TAGS SHALL BE GREEN IN COLOR
EXHIBIT "B"**

5 1/4"

**DO NOT REMOVE
BY ORDER OF
THE STATE FIRE MARSHALL**

**NAME
ADDRESS
TELEPHONE**

Cert. #

CERT. OF REG. NO.

NAME

LICENSE NO.

SIGNATURE

TYPE OF WORK PERFORMED

INSTALLATION
SERVICE
INSPECTION
MAINTENANCE

1	2	3	4	5	6	7	8	9	10	11	12	13	14	15
16	17	18	19	20	21	22	23	24	25	26	27	28	29	30
31														

Jan	Feb	Mar	Apr	May	June	July	Aug	Sept	Oct	Nov	Dec
1993			1994			1995			1996		1997

TYPE OF SERVICE PERFORMED

OWNER'S NAME AND ADDRESS

Front

2.5/8"

Back

Fire Protection Sprinkler System
Service Tag
(Actual Size)

**ARKANSAS FIRE PROTECTION LICENSING BOARD
YELLOW TAG
YELLOW TAGS SHALL BE ANY YELLOW IN COLOR**

EXHIBIT "C"

Front

2.5"X"

Back

DO NOT REMOVE BY ORDER OF THE STATE FIRE MARSHAL

1	2	3	4	5	6	7	8	9	10	11	12	13	14	15
16	17	18	19	20	21	22	23	24	25	26	27	28	29	30
31														

YELLOW TAG

*Name & Address of Sprinkler Firm
Phone Number
SCR-Number*

RME's License Number

Printed name of serviceperson / inspector

Signature of authorized serviceperson / inspector

REPORT STATUS TO OWNER AND AHJ IN WRITING (within 5 business days)

JAN	FEB	MAR	APR	MAY	JUN	JUL	AUG	SEP	OCT	NOV	DEC
2005			2006	2007	2008	2009	2010				

5 1/4"

If the system is not compliant with the NFPA standard, at the time it was installed, attach this yellow tag to the applicable system riser. An authorized individual may remove this tag after a service tag has been attached indicating the condition has been corrected.

Name of Owner or Occupant

Address

Building No. or Location or System No.

List impairments not compliant with NFPA standards:

Fire Protection Sprinkler System Yellow Tag (Actual Size)

**ARKANSAS FIRE PROTECTION LICENSING BOARD
RED TAG
RED TAGS SHALL BE ANY RED IN COLOR
EXHIBIT "D"**

2.5x8"

Front

Back

5 1/4"

**DO NOT REMOVE
BY ORDER OF
THE STATE FIRE MARSHALL**

1	2	3	4	5	6	7	8	9	10	11	12	13	14	15	
16	17	18	19	20	21	22	23	24	25	26	27	28	29	30	31

NAME
ADDRESS
TELEPHONE

Cert.# _____

CERT. OF REG. NO. _____

NAME _____

LICENSE NO. _____

SIGNATURE _____

CONDEMNED

IMPAIRED

Dec.	Nov.	1997
Oct.	Sept.	1998
Aug.	July	1995
June	May	1994
Apr.	Mar.	1993
Feb.	Jan.	

OWNERS NAME AND ADDRESS _____

IMPAIRMENTS/COMMENTS: _____

Fire Protection Sprinkler System
Red Tag
(Actual Size)

ARKANSAS FIRE PROTECTION LICENSING BOARD
ADOPTED STANDARDS VIA 2007 AFPC/2006 IBC
EXHIBIT "E"

NFPA Standard reference number										
10—02	11—02	11A—99	12—00	12A—04	13—02	13D—02	13R—02	14—03	15—01	16—03
17—02	17A—02	20—03	22—03	24—02	25—02	30—03	30A—03	30B—02	31—01	32—00
33—03	34—03	35—99	40—01	51—02	51A—01	52—02	55-05	57—02	58—04	59A—01
61—02	69—02	72—02	80—99	85—04	86—03	92B—05	99—02	101—03	110—02	111—01
120—99	160—01	211—03	230—03	241—00	260—03	261—03	265—02	286—00	303—00	385—00
407—01	409—01	430—00	484—02	490—02	495—01	498—01	505—02	654—00	655—01	664—02
701—99	703—00	704—01	750—03	1122—02	1123—00	1124—03	1125—01	1126—01	1127—02	1142—01
2001—04										

**ARKANSAS FIRE PROTECTION LICENSING BOARD
EXHIBIT "F"**

TABLE A

INSPECTOR PREREQUISITE

INSPECTOR PREREQUISITES: To become an inspector one of the experience modifiers listed below must be fulfilled, along with any requirements, such as testing as indicated in the rules and regulations.

- Receive an Inspector License issued by this State prior to January 1, 2003
- NICET Level III Certification for Automatic Fire Sprinkler Layout
- NICET Level II Certification for Automatic Fire Sprinkler Layout with 6 years of experience
- NICET Certification for Inspection and Testing of Water Based Systems
- NFPA Certified Fire Inspector I (CFI) and 6 months experience
- B. S. Degree in an Abet Fire Protection Degree with 6 months of experience
- Apprenticeship Level III with 6 months of experience
- Apprenticeship Level II with 1 year of experience
- Apprenticeship Level I with 2 years of experience
- AFSA course on NFPA 25 with 1 year of experience
- NFSA 3-Day Inspection and Testing Technician NICET Level II Study Review Seminar and ITM for Water Based Fire Protection with 6 months experience
- Obtained the title and wages of "Foreman" by a certified firm for 3 years and passed tests over NFPA 13 and NFPA 25 administered by this Board
- Received Education and/or experience in a fire protection related field for 3 years along with 2 years experience and pass tests over NFPA 13 and NFPA 25 administered by this Board
- NICET Certified Inspector with 6 months experience
- OSU: Fire Sprinkler Inspector Training and Certification and Inspection, Testing and Maintenance of Automatic Sprinkler System with 6 months of experience.

Time Requirements: Above are based on a 40 hour week average

EXPERIENCE means installation or apprenticeship whereby one has worked with individuals who are recognized by the State as Competent Installers or Inspectors of Fire Sprinkler works. RMEs are accountable for making sure the installers have adequate exposure to testing and other inspector related job functions before endorsing them to the Board.

TABLE B

FIRE PUMP PREREQUISITES

FIRE PUMP INSPECTOR PREREQUISITES: Examples of proper training for Fire Pump Servicing include:

- NICET Certification as listed above and training by a Fire Pump Manufacturer
- OSU: Industrial Fire Pumps
- AFSA: Fire Pump Acceptance Testing and NFPA 20
- NFSA: Fire Pumps for Fire Protection Course with 9 months of experience

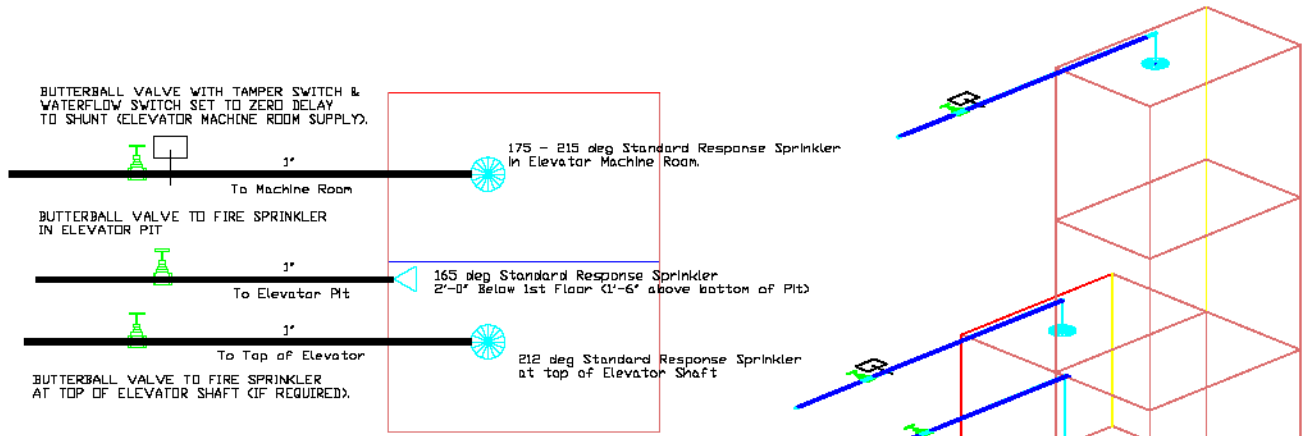

ELEVATOR PIT NOTES:

1. Fire sprinkler installed in pit due to accumulation of debris, though Fire Sprinkler Not Required per NFPA 13 for enclosed, noncombustible elevator shafts containing combustible hydraulic fluid.
2. A Supervised Shutoff Valve (Globe Valve with tamper switch), is required in the sprinkler supply line. Snake Detectors are disallowed per ASME A17.1 2.8.2.3.3 2000 ed.
3. ASME A17.1 Safety Code for Elevator & Escalators allows the Pit Sprinkler to be exempted from inhibiting waterflow until elevator recall has occurred (ie no waterflow switch required).
4. Pit Sprinkler can be Max 2 Ft above Pit Floor. 1'-6" will help ensure that it falls below the Elevator Toe Guard.

ELEVATOR MACHINE ROOM AND TOP OF ELEVATOR SHAFT

1. Fire Sprinkler Not Required in the top of noncombustible holstways of passenger elevator with car enclosure materials that meet ASME A17.1 requirements due to FS 0 to 75.
2. The Waterflow Switch shall be set to Zero Delay to Shunt Trip disconnect the Main Power Supply.
3. A Supervised Shutoff Valve (Globe Valve with tamper switch) is required in the supply to the sprinkler. The water flow switch is located downstream of this Shutoff Valve.
4. A means for testing the Waterflow Switch must be provided (plugged orifice downstream)
5. Sprinkler piping shall serve one level in the holstway (no vertical runs in the holstway) except where the Elevator Machine Room is on the roof above the shaft.
6. With questions pertaining to Fire Sprinkler installations in elevators, contact Chief Elevator Inspector for the Dept of Labor, Larry Smothers 501-682-4530 or fax 501-682-1765.